

Design And Construction Of A Mini Biodiesel Production Plant

Essien, P. J.¹

Department of Mechanical Engineering
Akwa Ibom State University, Ikot Akpaden, Mkpato Enin,
Akwa Ibom State, Nigeria
essienovic.pe@gmail.com

Iniobong E. Abasi-obot²

Department of Electrical and Electronic Engineering
Akwa Ibom State University, Ikot Akpaden,
Akwa Ibom State, Nigeria
iniobongabasiobot@aksu.edu.ng

Markson, I. E.³

Department of Mechanical
Engineering University of Uyo,
Uyo Akwa Ibom State, Nigeria
idorenyinmarkson@uniuyo.edu.ng

Abstract— In this paper, design and construction of a mini biodiesel production (MDP) plant is presented. The MDP plant comprises of containers for mixing and storing of the product, pump, heaters, thermometer, pipes, frames and a movable base. In this work, the MDP plant utilizes waste vegetable oil (WVO) collected from restaurant, canteens, hotels and factories as the feedstock. Specifically, the mathematical models for the computation of the various parameters pertaining to each of the key components of the MDP plant are presented after which the construction of the components are implemented based on the specified and computed design parameters. The isometric view of designed sample designed MDP plant is presented along with the picture of the constructed plant. The sample designed MDP plant operates in a batch system that takes 60 liters of vegetable oil as feedstock daily. The required power rating of the heaters amounted to 3 kW while the energy consumption of the pump is 1.242 kWh.

Keywords— Biodiesel Production Plant, Waste Vegetable Oil, Transesterification Reaction, Methoxide Tank, Biodiesel

1.0 INTRODUCTION

Across the globe, the demand for biodiesel production plants is growing due to the acceptance of biodiesel as a suitable alternative for diesel engines because of its biodegradability, renewability and reduced harmful emissions (Supriyanto, Sentanuhady, Dwiputra, Permana and Muflikhun, 2021). In any case, despite the growth witnessed in the biodiesel industry in Europe, Asia, and America, the same cannot be said about Nigeria

(Ogunkunle and Ahmed, 2019; Dahunsi, Fagbiele and Yusuf, 2020; Hassan and Ayodeji, 2019). The continuous dependence on fossil fuels poses several challenges ranging from uncertainty of supply, fluctuation in prices and environmental concerns (Zahraee, Shiwakoti and Stasinopoulos, 2020; Bashir, Bashir, Raza, Bilal and Vasa, 2023; Kalair, Abbas, Saleem, Kalair and Khan, 2021). Hence, if steps are taken to encourage the design and production of the biodiesel production equipment locally, it will facilitate local production of biodiesel, provide an alternative energy source, and also enhance reliance on local technology.

Accordingly, this work presents the design and construction of a mini biodiesel production (MDP) plant that is portable, affordable and efficient. The MDP plant utilizes waste vegetable oil (WVO) collected from restaurant, canteens, hotels and factories as the feedstock (Elias, Rabi, Okele, Okudoh and Oyekola, 2020; Dey and Ray, 2020; Al-Balushi and Rao, 2019). Specifically, the mathematical models for the computation of the various parameters pertaining to each of the key components of the MDP plant are presented after which the construction of the components are implemented based on the specified and computed design parameters. Thereafter, the MDP plant is constructed from mainly locally sourced components.

2.0 Description and analytical models for the design of the mini biodiesel production plant

The mini biodiesel plant consists of a number of key components, namely, the containers for mixing and storing of the product, pump, heaters, thermometer, pipes, frames and a movable base.

2.1 Dimension of the containers for mixing and storing of the product

The mini biodiesel plant comprises of three containers; a smaller frustum bottom container used for the

mixing of methanol and the catalyst, the larger frustum bottom container used for carrying out the transesterification reaction, the frustum bottom containers were selected to enable easy settling of the glycerol at the bottom. The third container is used for storing of the vegetable oil before being introduced to the reactor. The capacity of the reactor is given as;

$$V = \pi R^2 H + \left(\pi * \frac{1}{3}\right) (r_1^2 h_1 - r_2^2 h_2) \quad (1)$$

where V is volume of complete shape, H is the height of the cylindrical section, R the radius of cylindrical section, r the radius of frustum, h the height of frustum.

2.2 Pump Selection

The pump serves two purposes; transfer of fluid and recirculation or agitation of the mixture in the tanks (Zhang *et al.*, 2003). The main criteria considered is that the pump should be capable of recirculating about 75 litres of fluid four times within 15 minutes (or 0.25 hour). Based on the stated values, the estimated pump capacity required for the plant is computed as pump capacity (L/hr) = 75L/0.25hr = 300 L/hr.

Hence, the pump capacity should be around 300 L/hr. A pump with lesser capacity will result in longer mixing time. In this work, a centrifugal pump made of cast iron is selected. During selection of pumps the following key parameters are usually considered; flow rate of the reactor, the total pressure head and pump horsepower. The capacity (delivery or flow rate) of the reactor which is denoted by letter Q with dimension in m^3/h , $1/S$ is given as;

$$Q = VA = (\sqrt{2gZ})(\pi r^2) \quad (2)$$

Where: V is velocity of flow, A the cross sectional area of pipe, Z= head of fluid above the nozzle, G = acceleration due to the gravity = 9.81 m/s^2 , r = radius of pipe.

The head denoted by letter H and has dimension in meters and the power consumption (shaft power) denoted by letter P. The static head (H_S) of the reactor is given as;

$$H_S = H_2 - H_1 \quad (3)$$

Where H_2 is height of discharge fluid surface, H_1 is height of suction pipe fluid surface. The friction head loss is given as;

$$H_f = f \times \frac{l}{D} \times \frac{v^2}{2g} \quad (4)$$

Where l is the length of pipe, D diameter of pipe, f a constant that ranges from 0.01 to 0.04, V average fluid velocity and g acceleration due to gravity. The total pressure head (H) is obtained by adding the static head (H_S) and the friction head (H_f);

$$H = H_S + H_f \quad (5)$$

The pump horsepower is given as;

$$P = \frac{QHS}{3,960\mu} \quad (6)$$

Where P is the Power, hp, Q the Flow rate, gpm, S the Specific Gravity of fluid, H the Head height, ft and μ the Efficiency coefficient.

2.3 Selection of the Pipe

The selection of pipe diameter is governed by anticipated flow rate and the pressure head available. The diameter of the pipe is determined from the expression for the flow rate, Q given in m^3/s as $Q = VA$ where V is the average velocity in m/s and A is the cross sectional area of the pipe in m^2 . Then,

$$Q = \frac{\pi d^2}{4} \times V \quad (7)$$

$$Q = \frac{3.142}{4} \times d^2 \times V \quad (8)$$

Making V the subject of the formula, gives:

$$V = \frac{1.274Q}{d^2} \quad (9)$$

The anticipated values of V and Q are obtained from handbook of piping design (Sahid, 2011, Sahu, 1998). Taking V = 1.4 m/s and $Q = 2.5 \text{ m}^3/\text{hr} = 0.000694 \text{ m}^3/\text{s}$, the diameter d is then calculated as 0.989 inch. Therefore the diameter of the pipe is taken to be an approximate value of 1 inch which is 25.4 mm.

2.4 Selection of the Electric Heater

The mini biodiesel plant operates in a batch system that takes 60 liters of vegetable oil as feedstock daily. The 60 litres of vegetable oil used as the feedstock is required to be heated within a reasonable amount of time. Now, the density of the oil is assumed to be 0.91 Kg/L, the mass of oil in the 60 liters tank is calculated to be 54.6 Kg. A reasonable amount of time to heat the oil was set at 15 minutes. The specific heat capacity of vegetable oil is assumed to be 2.34 KJ/KgK. With a base temperature of 25°C, the oil is expected to be heated to maximum temperature of 60°C. The capacity of the heating element is given as;

$$Q = M_o C_o (T_2 - T_1) \quad (10)$$

The heater electric power is given as;

$$P_H = \frac{Q}{\text{delivery time (sec)}} \quad (11)$$

Where C_o is the oil specific heat capacity, M_o is the mass of oil, T_2 is the final temperature during reaction and T_1 is the initial temperature of oil. The quantity of heat transferred to the 60 L of oil was calculated as 4471 kJ. The power rating of the heaters amount to 3 kW, hence the delivery time was calculated as 993 seconds or 16 minutes.

2.5 Calculation of the Electrical Energy Consumption

The total electricity consumption of the plant is a sum of the power ratings of the circulation pump and the heating element. The electricity consumption of the pump is given as;

$$\text{Power [kW]} = \text{HP} \times 0.7457 \quad (12)$$

Where HP is the horsepower rating of the pump which in this work is 1hp. Hence, the pump power is calculated as

0.7457 kW. The energy consumption of the pump is given as;

$$\text{The energy consumption of the pump} = (\text{Power}) \times (\text{Operating Hours}) \quad (13)$$

The total operation time for the pump is 100 minutes. Hence, the energy consumption of the pump is 1.242 kWh, where the energy consumed by the heater (P_H) in Kwh is computed as follows;

$$Q = M_o C_o (T_2 - T_1) \quad (14)$$

$$P_H = \frac{Q}{\text{delivery time (sec)}} \quad (15)$$

2.6 Construction Procedure for the Mini Biodiesel Production Plant

The design and production of the plant involved the use of electrical, plastic, metal and wooden components. The materials were selected for the various parts after several considerations and ergonomics also played a part in the construction of the mini biodiesel production plant. The key components of the plants that were purchased or constructed are as follows;

Thermometer: The thermometer was used to detect the temperature of the reaction and also to ensure that the temperature of the reaction of vegetable oil and methoxide does not exceed 60 °C to avoid boiling of methanol.

Digital pH Meter: The device is used to check the alkalinity or acidity of the vegetable oil so as to determine the amount of sodium hydroxide to be added to the methanol for a complete reaction to occur. It is also used to check the pH of the biodiesel after the washing operation.

Centrifugal Pump: The pump is used for transfer of fluid between the two containers. It also serves the purpose of recirculation or mixing of the methoxide and vegetable oil during the reaction. It is electrically powered and made from cast iron.

Electric Heater: The heater is used to raise the temperature of the vegetable oil, maintain the reaction temperature and for drying the washed biodiesel.

CPVC Pipes: The pipes are used as a channel for flow of the fluids during the production process. They are connected to the pump and tanks with the aid of fittings and elbows.

Valves: The valves are used to control the flow of the fluid within the pipes during the process.

2.6.1 Construction of the base and frame of the mini biodiesel production plant

The base is a 6 mm wooden material with dimension 120 cm × 60 cm. The pump, structural frames and control board are mounted on this base. This ensures the stability and rigidity of the mini plant during operation. The base is also connected to four movable wheels for ease of transportation. The frame is the main supporting structure upon which the methoxide tank and reactor is mounted on. The methoxide tank is supported by a framework of 5 mm square pipe. The reactor tank is also supported by a framework of 15 mm square pipe.

2.6.2 Construction of waste vegetable oil tank

Waste vegetable oil (WVO) collected from restaurant, canteens, hotels and factories are poured into the WVO tank of 200 litre capacity. A strainer (filter) was fitted at the receptacle of the tank in order to prevent debris from entering the tank. The tank is made from carbon steel and has dimension of 850 mm height, 572 mm diameter and 3 mm thickness. A hole of diameter 28 mm was drilled about 30 mm above the bottom to provide a channel through which a pipe is fitted for conveyance of the WVO to the reactor. Three heating elements of 1500 watts each were also inserted at different positions in the tank to ensure uniform distribution of heat when heating the vegetable oil.

2.6.3 Construction of the reactor and methoxide tank

The reactor is a 90 litres cone bottom tank made from metallic material. The hollow bottom is connected to a threaded tank adapter with a PVC ball valve fitted to it. A 27.5 mm hole was drilled at the top of the tank to allow pipe carrying fluid from the pump to be fitted in. A 90 degree elbow facing inside the tank was connected to the pipe with the aid of a 1" PVC fitting. A 1200 W electric heater is fitted to the reactor tank in order to produce the desired temperature for the reaction. The methoxide tank is a 50 litres cone bottom tank also made from metallic material. The tank is used for preparing a mixture of methanol and potassium hydroxide. A hole of 27.5 mm was drilled at the top of the tank to allow a pipe to be fitted in for recirculation of the fluid to ensure a proper mix. A strainer was inserted into the methoxide tank to prevent the KOH or NaOH pellets from flowing into the pump. A pipe network consisting of valves and fittings was made connecting the methoxide tank to the reactor and pump, thereby allowing for transfer of fluid between the two tanks. CPVC material was selected for the pipe because of its higher melting temperature and corrosion resistance. Another pipe was connected to the pipe coming from the bottom of the reactor with the aid of a T-Connector in order to serve as a discharge channel for the glycerol settled at the bottom after the reaction. A shower spray head is mounted above the top of the reactor tank in order to allow for the use of water mist in the washing of the crude biodiesel.

2.6.4 Construction of the Control Board

An arrangement of switches for the pump, heaters and pH meter were mounted on the wooden base. The electrical components were wired properly using suitable cables and the control board has a plug enabling it to be connected to electricity source.

3. RESULTS AND DISCUSSION

The dimensions of the key components of the plants are presented. Specifically, the dimensions of the reactor are presented in Figure 1 while the dimensions of the Methoxide Tank are presented in Figure 2. Also, the dimensions of the WVO tank are presented in Figure 3 while dimensions of the base framework are presented in Figure 4. The isometric view of drafted mini biodiesel production plant is shown in Figure 5 while the picture of

the constructed Mini Biodiesel Production Plant is presented in Figure 6.

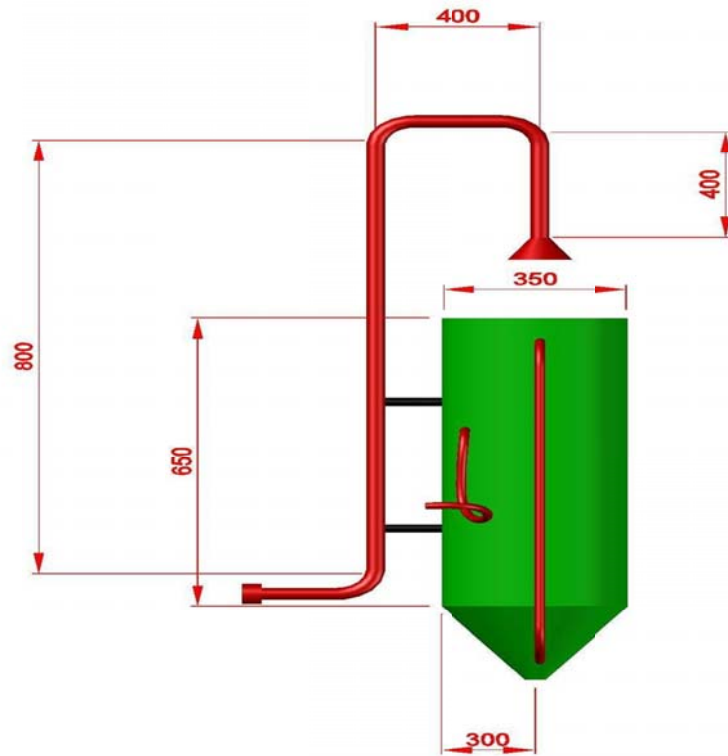

Figure 1 The Dimensions of the Reactor

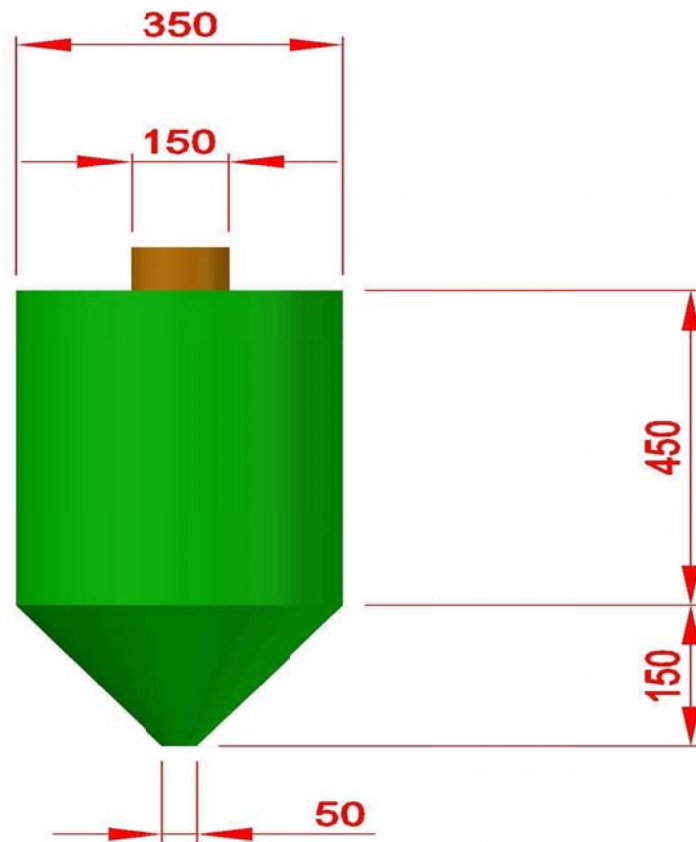

Figure 2 The Dimensions of the Methoxide Tank

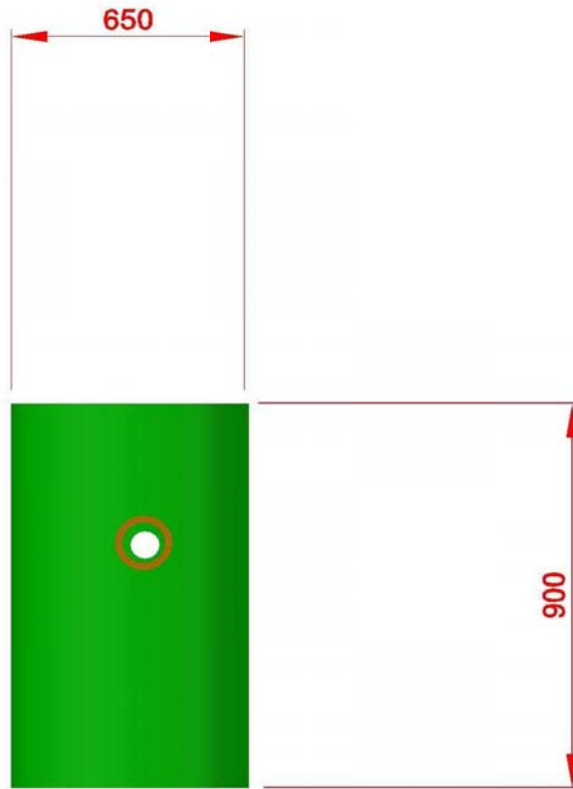

Figure 3 The Dimensions of the WVO Tank

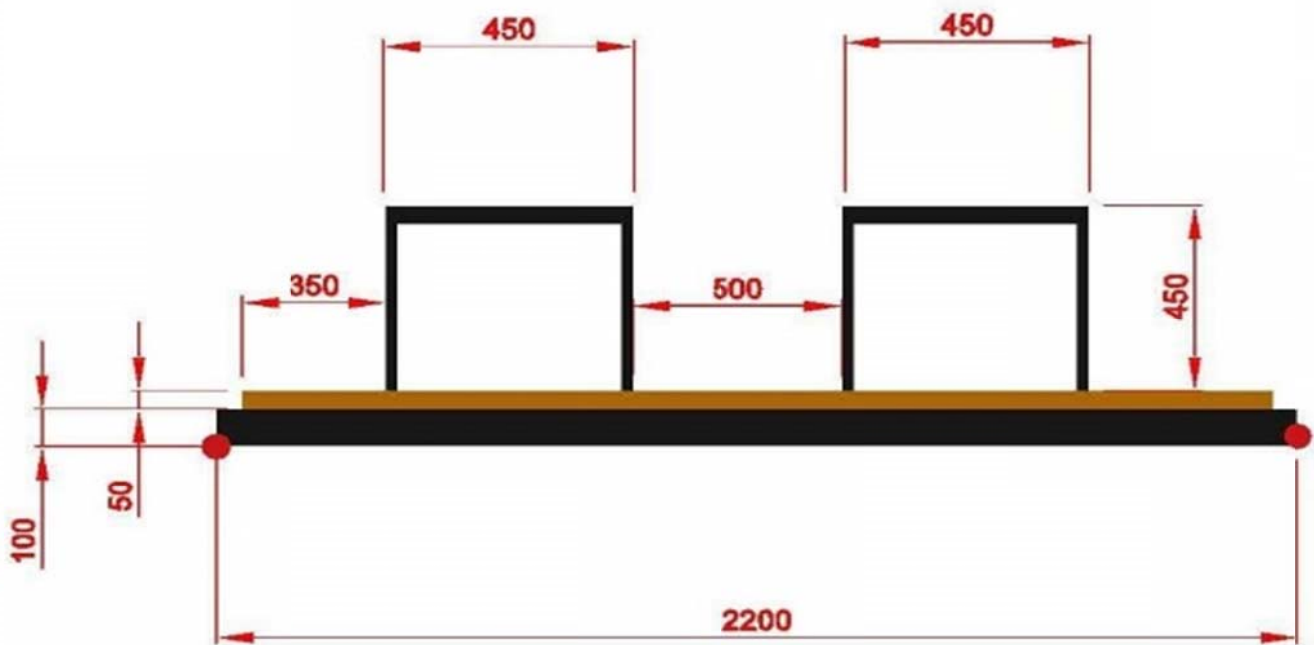

Figure 4 The Dimensions of the Base Framework

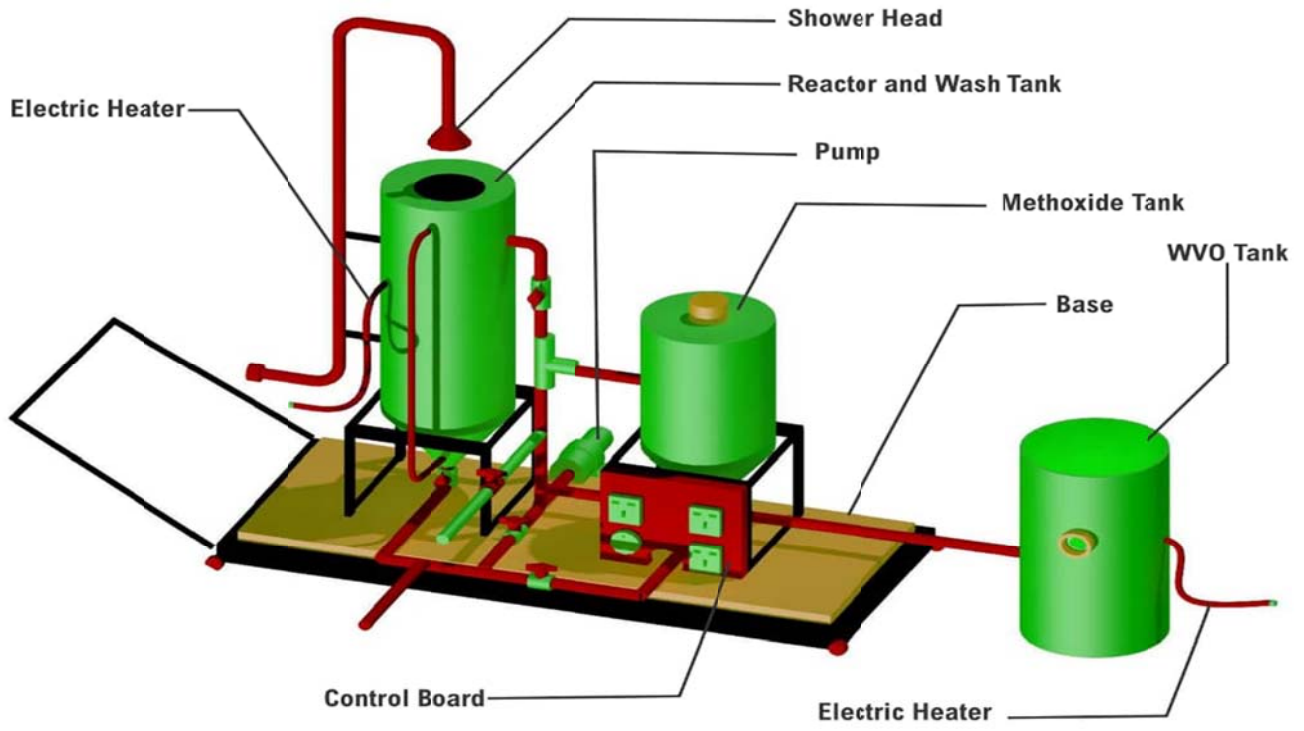

Figure 5: Isometric View of Drafted Mini Biodiesel Production Plant



Figure 6: Completed Mini Biodiesel Production Plant

4. CONCLUSION

The design calculations as well as the construction of a mini biodiesel production plant is presented. The key components of the mini biodiesel plant includes the containers for mixing and storing of the product, pump, heaters, thermometer, pipes, frames and a movable base. The feedstock for the mini biodiesel production plant is waste vegetable oil (WVO) collected from restaurant, canteens, hotels and factories.

First, the mathematical equations for the determination of the various parameters pertaining to each of the key components of the mini biodiesel plant are presented after which the construction of the components are implemented based on the specified and computed design parameters. The isometric view of drafted mini biodiesel production plant is presented along with the picture of the constructed plant.

REFERENCES

1. Adewuyi, A. (2020). Challenges and prospects of renewable energy in Nigeria: A case of bioethanol and biodiesel production. *Energy Reports*, 6, 77-88.
2. Al-Balushi, A. A. Y., & Rao, L. N. (2019). Comparative Studies on Production of Biodiesel from Waste Vegetable Oil (WVO) and *Noctiluca scintillans* (NS). *International Journal of Renewable Energy and Its Commercialization*, 5(1), 23-36.
3. Bashir, M. F., Bashir, M. A., Raza, S. A., Bilan, Y., & Vasa, L. (2023). Linking gold prices, fossil fuel costs and energy consumption to assess progress towards sustainable development goals in newly industrialized countries. *Geoscience Frontiers*, 101755.
4. Dahunsi, S. O., Fagbiele, O. O., & Yusuf, E. O. (2020). Bioenergy technologies adoption in Africa: a review of past and current status. *Journal of Cleaner Production*, 264, 121683.
5. Dey, P., & Ray, S. (2020). Comparative analysis of waste vegetable oil versus transesterified waste vegetable oil in diesel blend as alternative fuels for compression ignition engine. *Clean Technologies and Environmental Policy*, 22, 1517-1530.
6. Elias, S., Rabi, A. M., Okeleye, B. I., Okudoh, V., & Oyekola, O. (2020). Bifunctional heterogeneous catalyst for biodiesel production from waste vegetable oil. *Applied Sciences*, 10(9), 3153.
7. Hassan, A. B., & Ayodeji, O. V. (2019). Benefits and challenges of biodiesel production in West Africa. *Nigerian Journal of Technology*, 38(3), 621-627.
8. Kalair, A., Abas, N., Saleem, M. S., Kalair, A. R., & Khan, N. (2021). Role of energy storage systems in energy transition from fossil fuels to renewables. *Energy Storage*, 3(1), e135.
9. Ogunkunle, O., & Ahmed, N. A. (2019). A review of global current scenario of biodiesel adoption and combustion in vehicular diesel engines. *Energy Reports*, 5, 1560-1579.
10. Sahu, G. K. (1998). *Handbook of Piping Design*. New Age International.
11. Shahid, E.M.J. and Younis, H. (2011). Production of biodiesel: a technical review. *Renewable and Sustainable Energy Review*, 15: 4732-4745.
12. Supriyanto, E., Sentanuhady, J., Dwiputra, A., Permana, A. and Muflikhun, M. A. (2021) The recent progress of natural sources and manufacturing process of biodiesel: a review. *Sustainability*, 13(10), 5599.
13. Zahraee, S. M., Shiwakoti, N., & Stasinopoulos, P. (2020). Biomass supply chain environmental and socio-economic analysis: 40-Years comprehensive review of methods, decision issues, sustainability challenges, and the way forward. *Biomass and Bioenergy*, 142, 105777.
14. Zhang, Y., Dube, M. A., McLean, D. D. and Kates, M. (2003). Biodiesel production from waste cooking oil: 2. Economic assessment and sensitivity analysis. *Bioresour. Tech.*, 90 (3): 229-240.